

## Design of Chamber and Wells Turbine for an Oscillating Column of Water for Extracting Wave Energy from Anzali Port

Ahmad Sedaghat<sup>1</sup>, Ahmad Reza Zamani<sup>2</sup>

<sup>1</sup>Department of Mechanical Engineering, Isfahan University of Technology, Isfahan 84156-83111, I.R. of Iran (sedaghat@cc.iut.ac.ir)

<sup>2</sup>Subsea R & D Center, Isfahan University of Technology, Isfahan 84156-83111, I.R. of Iran (arzamani@cc.iut.ac.ir)

### Abstract

Renewable energies such as wave energy, despite rapid technological progress and potentials in Iranian waters, are yet require careful studies. Recent developments of marine energy in the world can manifest itself for energy demands in Iran. In this paper, the procedure for design of Well's turbine and Oscillating Water Column (OWC) containers are explained. Experimental wave measurements from Anzali port is used to design the system of OWC. Optimum sizes of the OWC container and Well's turbine are derived for using the maximum accessible wave energy in Anzali port.

**Key Words:** Wave Energy, Oscillating Column of Water System, Wells Turbine, Anzali Port.

### Introduction

In 1985, a complete example of OWC system was built in Norway. Since then, the use of this device is expanded so that similar devices were built in Japan (1990), India (1990), Portugal (1999), Iceland (2000), with outputs of 60-500 kW [1]. The important parts of the system in all samples were built are the chamber and the turbine which is installed in the upper part of the system. An example of the OWC system is shown in Fig. 1 and a sample of Wells turbine is shown in Fig. 2.

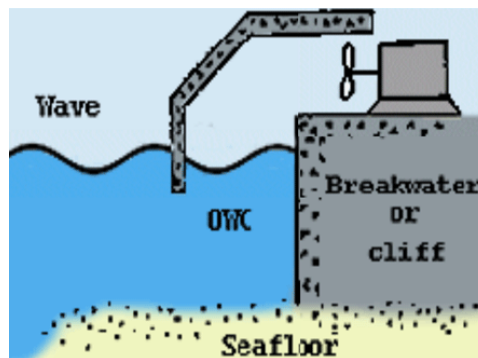
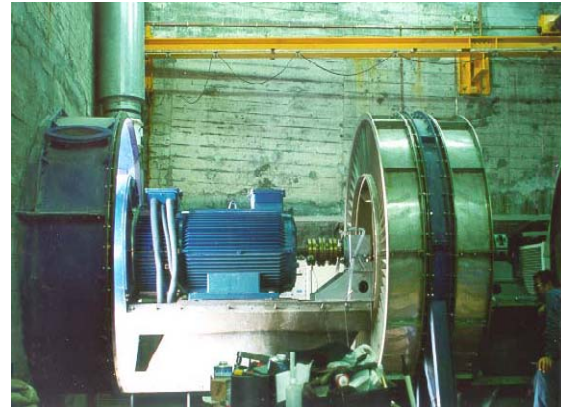
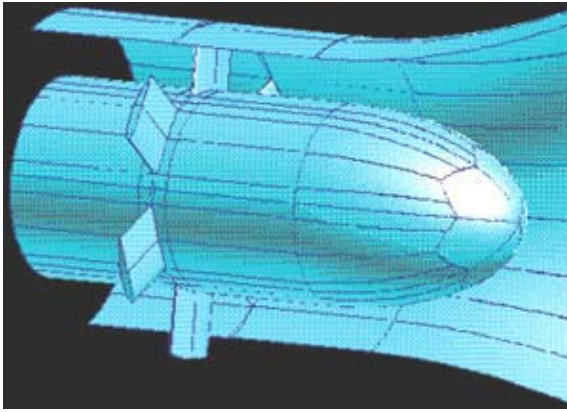

Fig. 1) The system of oscillating water column (OWC)



**Fig. 2) The schematic of Wells turbine (left) and the compartment of turbine and generator (right)**

### Theories Used in Design of Chamber and Turbine of OWC System

In pressure method, it is assumed that under the effect of wave pressure, the water level in OWC chamber increases. To determine the height of water in the chamber, Bernoulli equation is used [2]:

$$\frac{P_1}{\rho g} + \frac{v_1^2}{2g} + z_1 = \frac{P_2}{\rho g} + \frac{v_2^2}{2g} + z_2 \quad (1)$$

where the entering water (sea wise) is assigned with (1) and the exit side (air inside the chamber side) is assigned with (2). Pressure in inlet,  $P_1$ , is related to the wave pressure,  $P$ , by:

$$P_1 = P \sin(\omega t + \theta) \quad (2)$$

where Goda relations are used to relate the wave pressure to the wave characteristics as follow [3]:

$$P = 0/5 (p_1 + p_3)h' + 0/5 (p_1 + p_4)h_c^* \quad (3)$$

In this relation,  $h_c^*$  possess the minimum of  $h_c$  and  $\eta^*$ . In Fig. 3, the components of the pressure method is shown.

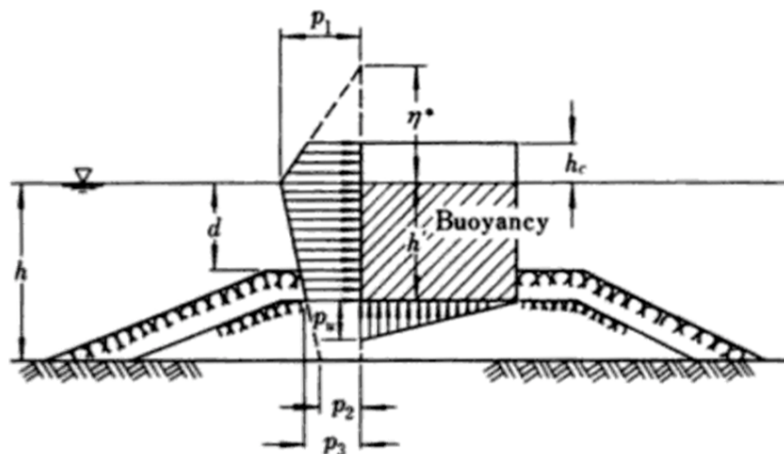

**Fig. 3) The schematic of various parameters in the pressure method [4]**

### Analysis of the measured wave data in Anzali port

As shown in Figs. 4 to 6 for obtaining the most probable effective height and wave period, the two-dimensional histogram for wave experimental data are shown. Similarly, the 3D histogram to find the most probable height and period for experimental data is shown.

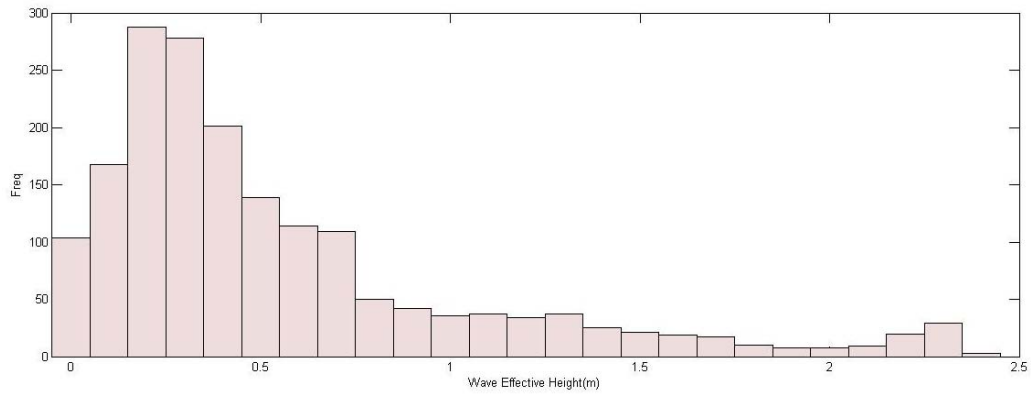

**Fig. 4) 2D Histogram for the effective wave height for 4 months data in Anzali port**

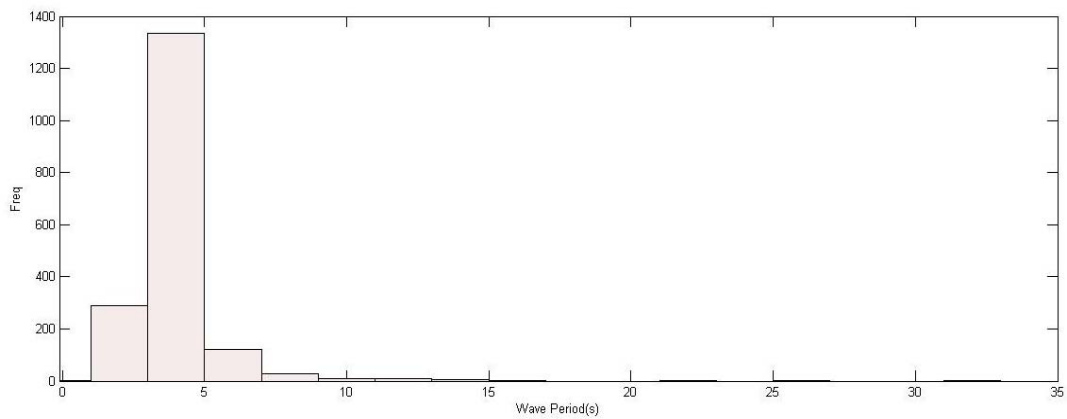

**Fig. 5) 2D Histogram for the wave period for 4 months data in Anzali port**

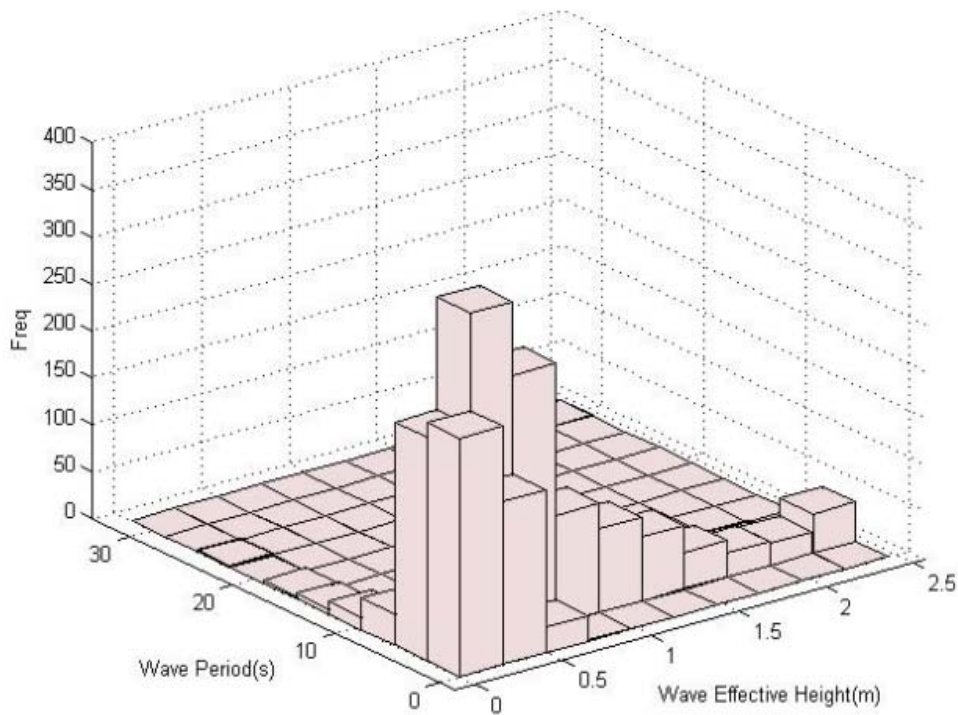
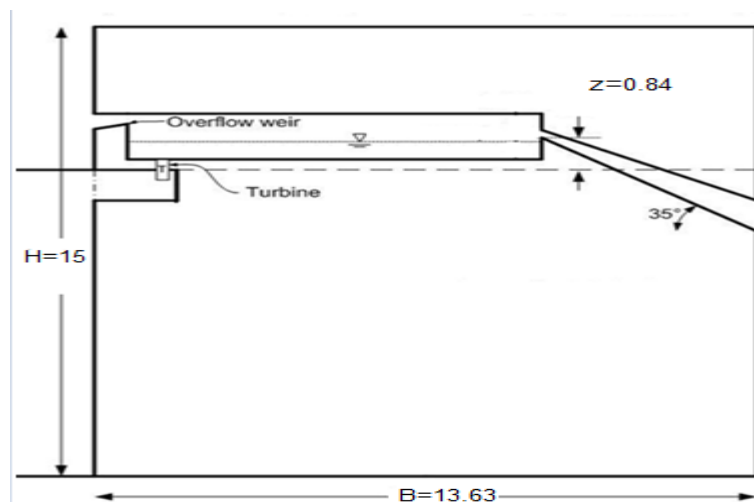

**Fig. 6) 3D Histogram for the effective wave height and wave period for 4 months data in Anzali port**

Thus, it is observed that for the available experimental data, the most probable effective height is 0.25 meters, and the most probable wave period is 5 seconds. In practice, the measured data for the periods of 5 to 10 years are required.

### **Results of Design for OWC Chamber and Wells Turbine**

With regards the experimental data for Anzali port and the maximum wave height of 2.54 meters, the optimum sizes of the OWC chamber is calculated as shown in Fig. 7.



**Fig. 7) Final sizing of the chamber using 4 months wave data in Anzali port**

According to table 1, the optimum values for the system is determined as 1.05 meters in diameter, 8 bladed Wells turbine with NACA0015 aerofoil, with efficiency of 5.5% and the output power of 1.4 kW for each turbine.

**Table 1) Output power and efficiency of Wells turbine for different aerofoils with different number of blades and d=1.05 m**

Blades Numbers	NACA 0012		NACA 0015		NACA0018	
	Output power (W)	Turbine efficiency (%)	Output power (W)	Turbine efficiency (%)	Output power (W)	Turbine efficiency (%)
5	stall	stall	879.538	3.430	816.138	3.183
6	stall	stall	1055.446	4.116	979.365	3.819
7	stall	stall	1231.353	4.802	1142.593	4.456
<b>8</b>	stall	stall	<b>1407.261</b>	<b>5.488</b>	1305.821	5.092

## Conclusions

Using the renewable energies such as wave energy, from technology or cultural point of view, despite available potentials, requires research studies. From the experiences in the recent few years, it is observed that the wave energy can be placed among other sources of energy in Iran. In this paper, the design and theories related to OWC systems and Wells turbine are presented and then from the experimental data for waves in Anzali port, the chamber of OWC system and Wells turbine is designed using programming in Matlab software. At the end, the optimum dimensions of the chamber and the corresponding Wells turbine for using maximum possible wave energy for the OWC system are obtained.

## References

- [1] Holthuijsen, L.H. 2007. Waves in Oceanic and Coastal Waters, Cambridge University Press, Cambridge.
- [2] Schoolderman, J.E. 2009. Generating electricity from waves at a breakwater in a moderate wave climate, Delft University of Technology, Delft.
- [3] Schoolderman, J. et al. 2009. Generating electricity at a breakwater in a moderate wave climate, Proceedings of the International Conference on Coastal Engineering, pp. 37-49.
- [4] Burton, T. 2001, Wind Energy Handbook, J. Wiley.